



Schindler 2400

An eye for mass and love for detail is not a contradiction in terms.

When it comes to our service elevators, those terms are our guide.





The Schindler 2400 fits.

It can be used anywhere. In shopping centers and convention buildings, in airports and train stations, in hotels, schools, and office complexes. An absolutely presentable elevator.

A blurred photograph of a person walking through a glass door. The person is wearing a light-colored top and dark pants. The background is bright and out of focus. In the foreground, a brown shopping bag is partially visible on the left. The word "satility" is overlaid in white text on the lower half of the image.

satility



Availabil

The Schindler 2400 keeps running.

With absolute reliability. Whoever you want and whenever you want. A simply uncomplicated matter.





Longe

The Schindler 2400 keeps its promises.
Thanks to its robust technology, high-quality materials, and practical equipment features. A consummate achievement.

A photograph of a woman with long, wavy brown hair wearing a bright red, sleeveless, form-fitting dress. She is standing on a modern staircase with glass railings and is embracing a man from behind. The man is wearing a white long-sleeved shirt and grey trousers. The scene is brightly lit, suggesting an indoor setting with large windows or skylights. The word "vity" is overlaid in white text on the left side of the image.

vity



Are you looking for an intelligent solution? No need to look very far.

Brisk movement is our business

You need an elevator for a building with high visitor traffic? One that can hold shopping carts as well as people, and transport various types of goods? Then the Schindler 2400 is the right choice.

We have developed an extra-large service elevator especially for high-traffic public and private buildings. It fits in hotels as well as it does in shopping centers, office buildings, hospitals, train or underground train stations. It's economical to purchase and robust in use.

Simple solutions are our approach

With the Schindler 2400, we rely on consistent system engineering and high standardization. For this reason, we've given this elevator a modular construction. It is based on pre-assembled components that reflect the latest technology. The elevator's availability is absolutely reliable. Depending upon your needs, the drive may be electromechanical or electro-hydraulic.

Safety comes first with us

We monitor the system 24 hours a day, 365 days a year. That way, problems can be corrected before they affect you. Even during the night.

We only grant access to those you want to have it

With high incoming traffic, it's important to secure the flow of traffic as efficiently as possible. This is where our registered-destination control system does a great job. Together with the brand-new SchindlerID, the elevator can be made available only to specific persons at specific times if desired. There are practically no limits to the ways the new technology can be configured to meet your needs. An ingenious system.

We're happy to take on commitments

The elevator meets all significant legal safety regulations and standards.

You can call us into action from any location

The Schindler 2400 saves you time and money. Pre-defined components and mandatory data, ease planning and shorten delivery times – for a single system or a group of up to four elevators. The Schindler 2600 freight elevator and the Schindler 2500 bed elevator belong to the same platform as the service elevator.

Notice

We reserve the right to make technical modifications and to alter specifications, options and colors.

All cars and options presented in this brochure are intended to serve as representations of our products. Colors and materials as shown may vary from the original.

Basic data

Load capacity	630–2500 kg, 8–33 persons
Travel height	65 meters; max. 21 stops
Entrance	One-sided or two-sided access
Door width	800–2300 mm
Door height	2000–2400 mm
Drive	Roped or hydraulic
Speed	0.4 to 1.6 meters per second
Control	Collective control for groups up to 4; registered-destination control
Equipment	Flexible range of equipment

Success is a question of usefulness. Especially when it comes to service elevators.

Many people shop every day at shopping centers. In order for them to quickly get where they want to go, the coordination of the various traffic ways must be optimized, both horizontally and vertically. The Schindler 2400 fits perfectly into the bustling traffic of such a shopping paradise. The elevator brings not only people to their destination quickly and reliably – it also transports shopping carts and heavy goods. Flexibly and efficiently.





Plants need care and protective transportation. It is a joy to unpack the fresh flowers.



Mommy and I have bought presents. The helicopter is for me.



Sunglasses have to fit the outfit. That's just common sense.



The proof of the pudding is in the eating. Go right ahead.

Drive	Load capacity Passengers max.		Speed	Travel height max.		Number of stops max.		Nominal rating	Nominal current	Car			Door			Shaft	
	GQ kg			VKN m/s	*3 HQ m	ZE	*4 PMN kW			*4 INN A	*5 BK mm	*5 TK mm	*5 HK mm	Type	*6 BT mm	*6 HT mm	*7 HSG mm
Rope *1	1000	13	1.00	42	21	10.8	23	1000–1600	1400–2350	2100–2500	T2/C2/C4	800–1600	2000–2400	1500	HK + 1500		
			1.60	65		18.9	30							1700	HK + 1650		
	1275	17	1.00	42	21	10.8	29	1100–1800	1500–2650	2100–2500	T2/C2/C4	800–1800	2000–2400	1500	HK + 1500		
			1.60	65		18.9	36							1700	HK + 1650		
	1600	21	1.00	42	21	10.8	30	1200–2100	1500–2900	2100–2500	T2/C2/C4	800–2100	2000–2400	1500	HK + 1500		
			1.60	65		22.8	43							1700	HK + 1650		
	2000	26	1.00	42	21	14.2	37	1400–2300	1650–2950	2100–2500	T2/C2/C4/C6	800–2300	2000–2400	1500	HK + 1500		
		1.60	42		22.8	49							1700	HK + 1650			
	2500	33	1.00	42	21	25.0	49	1400–2300	2050–3500	2100–2500	T2/C2/C4/C6	800–2300	2000–2400	1700	HK + 1700		
Hydraulic	630	8	0.63	18	8	11.0	28	900–1400	1000–1750	2100–2500	T2/C4	800–1400	2000–2400	1300	HK + 1300		
Rucksack *2	1000	13	0.63	18	8	14.7	35	1000–1600	1300–2300	2100–2500	T2/C4	800–1600	2000–2400	1350	HK + 1300		
	1275	17	0.63	18	8	20.0	45	1100–1800	1450–2600	2100–2500	T2/C4	800–1800	2000–2400	1450	HK + 1300		
	1600	21	0.63	18	8	29.0	63	1200–2100	1500–2900	2100–2500	T2/C4	800–2100	2000–2400	1450	HK + 1300		
	2000	26	0.40/0.63	18	8	40.0	86	1400–1500	2300–2900	2100–2500	T2/C4	800–1500	2000–2400	1450	HK + 1300		
Hydraulic	2000	26	0.40/0.63	18	8	40.0	86	1400–2300	1650–2950	2100–2500	T2/C2/C4/C6	800–2300	2000–2400	1150	HK + 1300		
Tandem *2	2500	33	0.40/0.63	18	8	47.0	98	1400–2300	2050–3500	2100–2500	T2/C2/C4/C6	800–2300	2000–2400	1250	HK + 1300		

GQ Load capacity
VKN Speed
HQ Travel height
ZE Number of stops
PMN Nominal rating
INN Nominal current

- *1 With or without machine room
- *2 Machine room under, over, or to the side; max. 10 m from shaft
- *3 Traction elevators with lift over 25 meters are not designed for trolleys with heavy loads
- *4 Maximum values

BK Car width
TK Car depth
HK Car height
*5 Car dimensions in 50-mm increments, the maximum allowed car area according to EN81 must be considered

T2 Telescope door, two-part
C2 Center-opening telescope door (two-part)
C4 Center-opening telescope door (four-part)
C6 Center-opening telescope door (six-part)
BT Door width
HT Door height
*6 Door dimensions in 100-mm increments

HSG Shaft pit depth
HSK Clear overhead below lifting beam
*7 Minimal values, in hydraulic variation must be increased in measure according to the configuration

Max. number of entrances: 2, opposing
Number of rides (rope): 180 per hour
Number of rides (hydraulic): 30/60 per hour
Power supply: 400 V; optional 230 V

Shaft width/depth: In the planning section on pages 20–23, ranges shown reflect typical elevator situations.

Car

We construct the car according to your wishes – width, depth and height – so that it perfectly matches the traffic volume in your building. Car frames make the car extraordinarily stable.

Door

We construct the ideal door for your needs – with two, four, or six panels. They efficiently exploit the width of the shaft and, if desired, can be made exactly as high and as wide as the car. This entails a number of advantages. Entering and exiting with shopping carts is convenient. It also helps avoid damage to the doors. And the opening and closing speed of the doors can be adjusted.

Standards

The Schindler 2400 is certified according to the Lift Directive 95/16/EC. In addition, it fulfills all relevant standards:

- EN81-28 Remote emergency calling system for passenger and cargo elevators
- EN81-58 Fire-resistant landing doors
- EN81-70 Accessibility of passenger elevators including persons with disabilities (as an option)
- EN81-71 Protective measures against intentional destruction (optional vandal-proof buttons and car equipment)
- EN81-72 Fire department elevator (optional)

Environment

The Schindler 2400 fulfills the requirements of ISO 14001. Both the traction and the hydraulic versions display very good energy consumption values. For the hydraulic elevators, a drive system can be selected as a standard feature, which has significantly lower energy consumption when compared with conventional hydraulic aggregates.

Monitoring

The Schindler 2400 is permanently monitored from our headquarters, 24 hours a day, 365 days a year. Problems are corrected preventatively.

For the development of our systems, we jump over every hurdle. Even the hurdles of our own intuition.

Traction elevator system

The Schindler 2400 can be driven electromechanically for loads of 1000 kg to 2500 kg. The traction elevator system is especially suitable for complexes with brisk traffic and where multiple elevators are used. By networking the elevators, the efficiency of transport can be increased. No machine room is necessary for up to 2.5 ton loads. That saves significant space in a building.

Drive

The highly efficient permanent-magnet-drive of the Schindler 2400 runs without gears, which increases its efficiency. Because it is relatively small and functions quietly, it represents the ideal solution for machine-room-less elevators in particular. The frequency-controlled drive provides comfortable movement without vibration. The elevator achieves excellent stopping accuracy. And in addition, it is economical when it comes to energy consumption.

Control

The microprocessor control of the Schindler 2400 ideally fulfills a wide variety of tasks, for individual systems as well as for groups of up to four elevators. Standard types of controls are: Pick-up, up or down collective, or collective-selective control for groups of up to four elevators. More than 100 control options are available as standard options for individual configuration.

As an Option the unique Schindler Miconic 10 registered-destination control system makes a particularly significant contribution. It analyzes the transport volume of the entire system and assigns the ideal car to each passenger. The result is short waiting times and short rides.

Access control

Passenger and cargo transport can also be controlled by a key switch or card reader.

With the Miconic 10 registered destination control, our new technology SchindlerID can be applied. SchindlerID is a completely new system architecture for elevator service and access control. The passenger and cargo transportation is controlled according to demand and target group. Passengers select their destination before they enter the elevator.

The controls are built into the top floor next to the landing doors, which saves space.

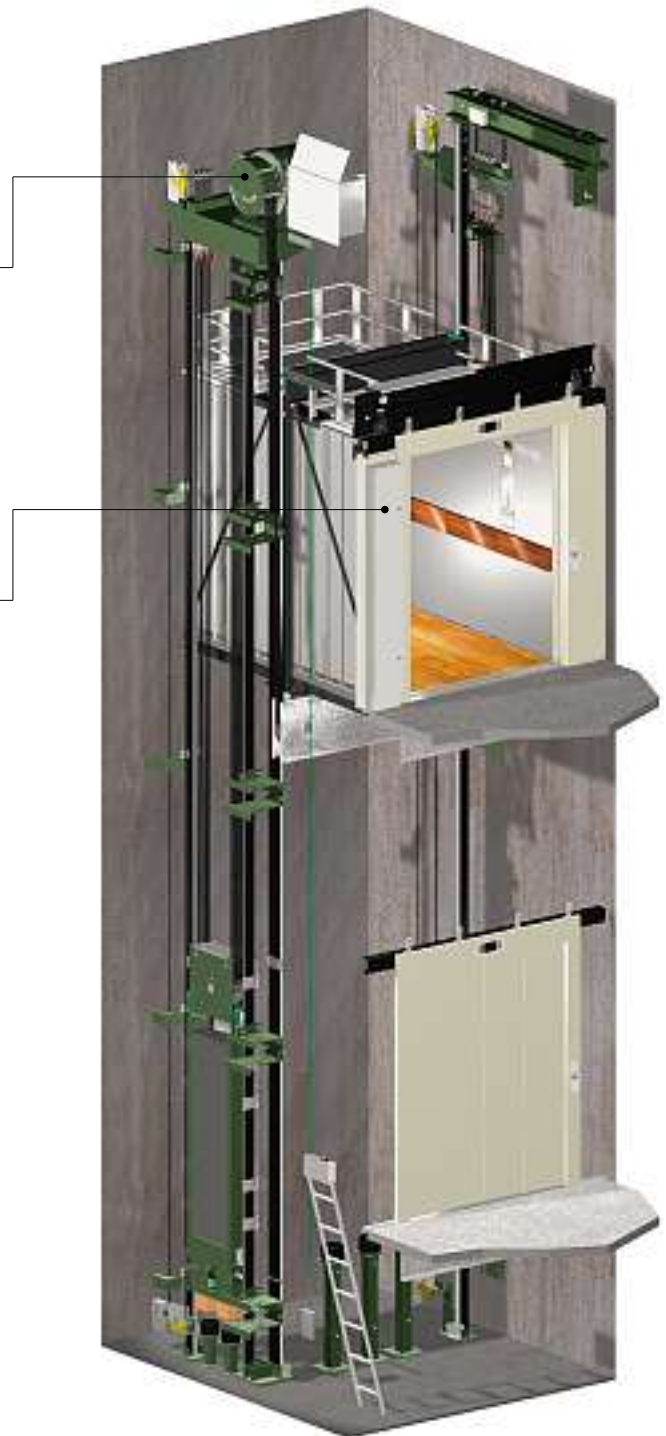

Machine-room-less traction elevator

Hydraulic elevator system

The Schindler 2400 can be driven electro-hydraulically with a load of 630 kg to 2500 kg. This is a suitable method, particularly for single-system applications. The hydraulic elevator system offers an extraordinarily economical solution for low-rise buildings.

Drive

The Schindler 2400 possesses a unique drive system. It consists of a pump unit and an electronically controlled valve. Combined with the integrated control, it reliably fulfills high demands and provides an extraordinarily comfortable ride. The drive achieves excellent stopping accuracy.

The hydraulic version of the Schindler 2400 also displays low energy consumption. The consumption levels lie within those of the traction elevators.

Control

The microprocessor control specially created for hydraulic elevators is suitable for a wide variety of needs and uses. It offers regulated control, which produces short ride times. You may select from the following typical control types: Pick-up, up or down collective, or collective-selective control for groups of up to four elevators. More than 100 control options are available as standard options.

Access control

The Schindler 2400 possesses access-control systems. Passenger or cargo transport can be controlled according to specific needs – such as by key switch or card reader, for example.



Tandem hydraulic drive

<p>Walls Car doors</p>	 <p>Skinplate/paint Catania Yellow</p>	 <p>Skinplate/paint Malmo Gray</p>	 <p>Skinplate/paint Lübeck Blue</p>	 <p>Skinplate/paint Aberdeen Green</p>
 <p>Stainless steel brushed</p>	 <p>Stainless steel diamond-pattern</p>	 <p>Stainless steel linen</p>		
				
				
				
<p>Ceiling Floor</p>	 <p>Ceiling Paint Trondheim White</p>	 <p>Ceiling Paint Catania Yellow</p>	 <p>Ceiling Paint Malmo Gray</p>	 <p>Ceiling Stainless steel brushed</p>
 <p>Floor Black studded rubber</p>	 <p>Floor Black structured rubber</p>	 <p>Floor Aluminum treadplate</p>		

To good to be true? Don't worry – this is no fairy tale.

Every day, the Schindler 2400 transports many people in wide variety of building types. In order for it to fit in anywhere, we rely on versatility of design. We present you with standard versions from which to choose, but we're also happy to meet your personal wishes with special materials and colors.

The car walls and doors in the standard version have a high-grade painting in various eye-pleasing colors. The same colors are also available in skinplate. Elegant stainless steel panels are also included in the carefully selected palette of options. We can also offer other colors or materials at similar delivery and price conditions upon request. Walls as well as doors may be partially or completely made of glass if desired.

Landing doors are painted gray, are constructed from stainless steel or, if desired, are in other color variations available.

For floors in our standard version, textured rubber flooring, black rubber flooring with gray structuring, or aluminum treadplate is available. Upon request, we will gladly install a natural stone flooring for you. The easy-care and slip-proof flooring withstands wear-and-tear and matches the elegant appearance of the elevator car.

A painted ceiling or ceiling of brushed stainless steel are also features of the Schindler 2400. The suspended lighted ceiling provides pleasant lighting in the car.

Simplicity means doing without. Doing without what's unnecessary.

Car and hall fixtures

The control panel in the car of the Schindler 2400 stretches to the entire height of the car. It is embedded flush with the wall of the car. This protects it from damage, such as damage that can occur when entering or exiting with shopping carts, for example.

The car and hall control panels are constructed from brushed stainless steel. The control panels in the car are also available in anthracite. Optional handicapped-accessible control panels for cars with voice-messaging or vandal-proof buttons are also available.

Hall control panels and floor indicators are mounted flush with the wall or into the door frame. The indicators can also be ordered with a gong sound.

Protective strips

The car is equipped with protective strips around its circumference.

They are constructed from

- black plastic,
- brushed stainless steel, or
- are specially constructed according to your wishes.

The baseboard for covering ventilation louvers in the floor are made of brushed stainless steel, and are included as standard equipment.

Thresholds

Car and landing door thresholds made of brushed stainless steel are available as an option.

Handrails

For safety, the service elevator can be equipped with handrails. They are

- straight or
- bent, and
- are made of brushed stainless steel.

Mirrors

If desired, the Schindler 2400 can be fitted with a mirror. As a standard feature, you can receive mirror that covers upper half of the car's height, placed on whichever car wall you desire.

We also gladly construct additional accessories for you – such as a display window for advertisements – precisely according to your wishes.

Overview of control panels



Floor level indicators
 – Standard
 – Vandal-proof



In-car fixtures, stretched to the entire car height
 – Stainless steel
 – Anthracite
 – Vandal-proof



Hall fixtures,
 individually configurable
 – 2-element
 – 5-element
 – Vandal-proof

Schindler ID/Miconic 10

Handrail



Many things can be conceived. Almost anything is possible.

Machine-room-less traction elevator with frequency-controlled drive
1000–2500 kg load capacity; 13–33 persons

Drive	Load capacity		Passengers max.	Speed	Number of entrances			Door			Shaft			
	GQ	VKN			BK	TK	HK	Type	BT	HT	BS	TS	HSG	HSK
kg	m/s	mm	mm	mm	mm	mm	mm	mm	mm	mm	mm	mm	mm	
Rope	1000	13	1.0	1	1100	2100	2300	T2	900	2100	1950	2550	1500	3800
				2		2050						2660		
	1000	13	1.0	1	1300	1750	2300	T2	1100	2100	2200	2200	1500	3800
				2		1700						2310		
	1600	21	1.0	1	1400	2400	2300	T2	1100	2100	2250	2850	1500	3800
				2								3010		
	2000	26	1.0	1	1500	2700	2300	C4	1300	2100	2350	3150	1500	3800
				2		2650						3260		
				2		2700			1500		2500	3230		
	2500	33	1.0	1	1800	2700	2300	C4	1600	2100	2950	3150	1700	4000
				2		2650						3260		
				2		2700			1800		3100	3230		

GQ Load capacity
VKN Speed

HQ Travel height
HE_{min} Minimal interfloor distance

BK Car width
TK Car depth
HK Car height

T2 Telescope door
C4 Center-opening telescope door (four-part)

BT Door width
HT Door height

BS Shaft width
TS Shaft depth

HSG Shaft pit depth
HSK Clear overhead below lifting beam

HE_{min} = HT + 740 mm for one-sided entrances
HE_{min} = 300 mm for staggered opposite entrances

For further details, such as offers, construction plans and prices, please contact our sales department directly.

Height and plan view

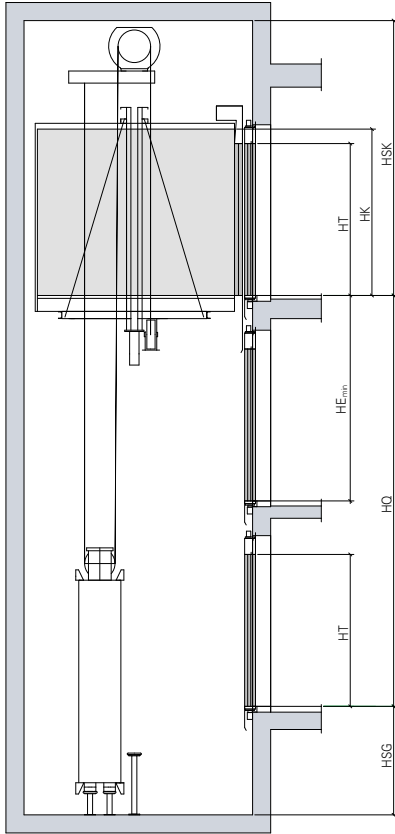

One-sided entrance

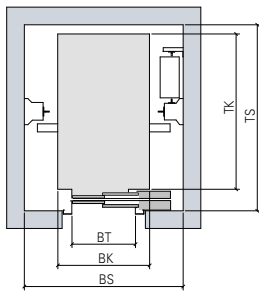

One-sided entrance
Telescopic door

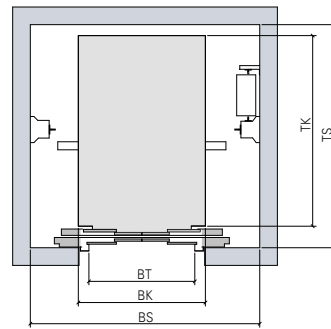

One-sided entrance
Center-opening telescopic door (four-part)

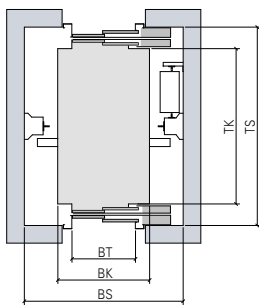

Two-sided entrance
Telescopic door

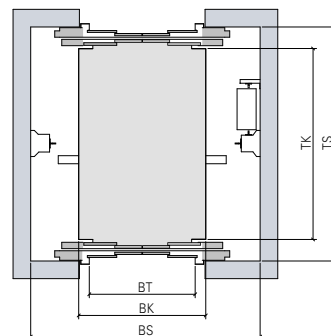

Two-sided entrance
Center-opening telescopic door (four-part)

It's a good feeling, not having to settle for average.

Hydraulic elevator with machine room
630–2500 kg load capacity; 8–33 persons

Drive	Load capacity		Passengers max.	Speed	Number of entrances			Door			Shaft			
	GQ kg	VKN m/s			BK mm	TK mm	HK mm	Type	BT mm	HT mm	BS mm	TS mm	HSG mm	HSK mm
Hydraulic Rucksack	630	8	0.63	1	1100	1400	2300	T2	900	2100	1700	1850	1300	3600
				2		1350						1960		
	1000	13	0.63	1	1100	2100	2300	T2	900	2100	1700	2550	1350	3600
				2		2050						2660		
	1000	13	0.63	1	1300	1750	2300	T2	1100	2100	2000	2200	1350	3600
				2		1700						2310		
	1600	21	0.63	1	1400	2400	2300	T2	1100	2100	2050	2850	1450	3600
				2								3010		
2000	26	0.40	1	1500	2700	2300	C4	1300	2100	2400	3150	1450	3600	
			2		2650						3260			
			2		2700			1500		2550	3230			
Hydraulic Tandem	2000	26	0.40	1	1500	2700	2300	C4	1300	2100	2400	3150	1150	3600
				2		2650						3260		
				2		2700			1500		2500	3230		
	2500	33	0.40	1	1800	2700	2300	C4	1600	2100	2800	3150	1250	3600
				2		2650						3260		
			2		2700			1800		2950	3230			

GQ Load capacity
VKN Speed

HQ Travel height
HE_{min} Minimal interfloor distance

BO Width of machine room
TO Depth of machine room

BK Car width
TK Car depth
HK Car height

T2 Telescope door
C4 Center-opening telescope door (four-part)

BT Door width
HT Door height

BS Shaft width
TS Shaft depth

HSG Shaft pit depth
HSK Clear overhead below lifting beam

HE_{min} = HT + 740 mm for one-sided entrances
HE_{min} = 300 mm for staggered opposite entrances

For further details, such as offers, construction plans and prices, please contact our sales department directly.

Height and plan view

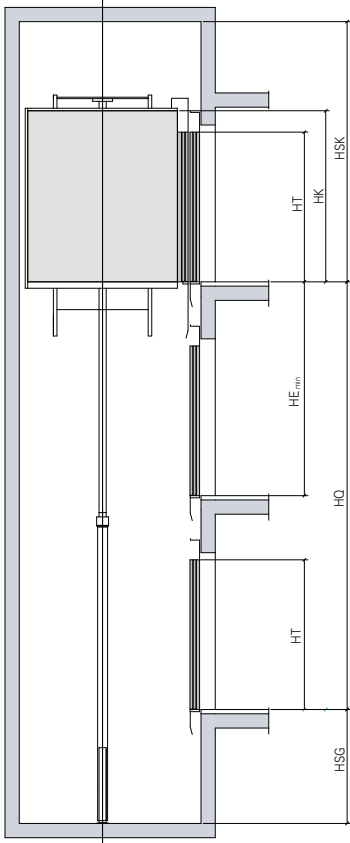

One-sided entrance
Rucksack system

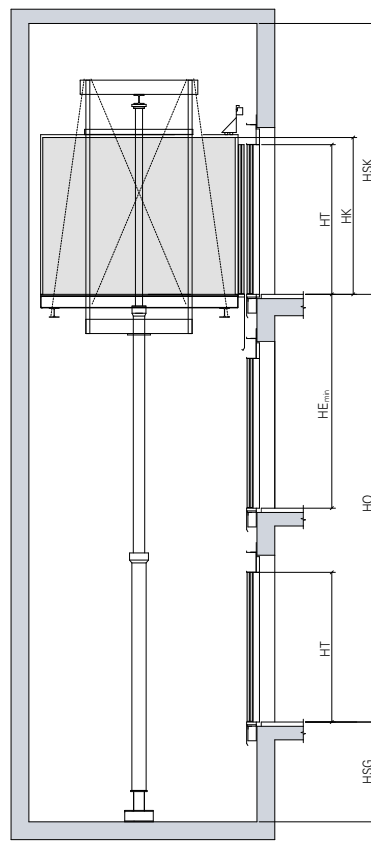

One-sided entrance
Tandem system

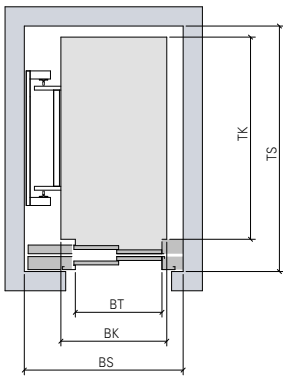

One-sided entrance
Telescopic door

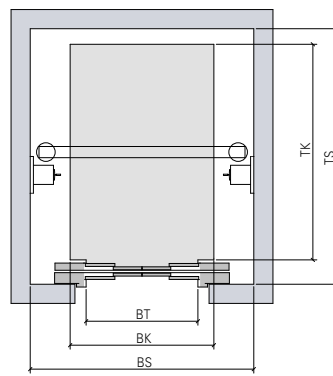

One-sided entrance
Center-opening telescopic door (four-part)

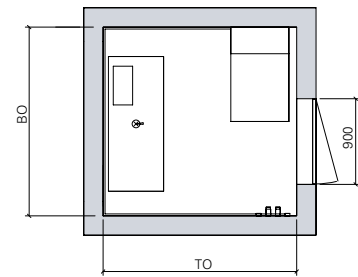

Machine room

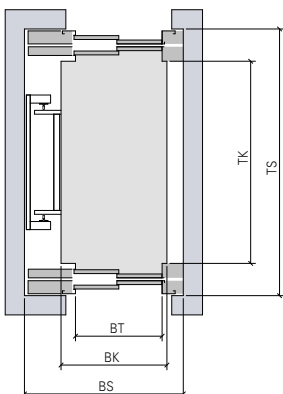

Two-sided entrance
Telescopic door

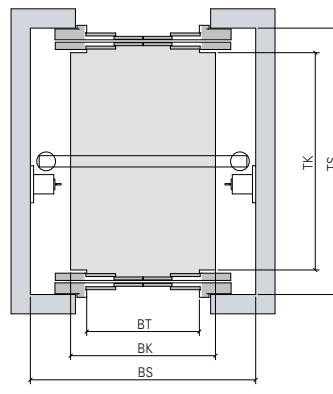

Two-sided entrance
Center-opening telescopic door (four-part)

It's nice when someone
always makes time for you.
Don't you agree?

For further information including the location
of the distributor nearest you, please visit:

www.schindler.com